



# FAW

# MODEL 33.330FC

MODEL	CA 33.330FC
Cab Control(1 Sleeping bunk Seating)	Forward (Elect. tilt)(Aircon)
Axle Configuration	Driver + 1 Passenger 6x4

ENGINE	
Make & model	Steyr WD 615.44
Capacity	9746 cub. cm.
Layout & type	Diesel, water cooled, 6 in line, 4 stroke, turbocharged & intercooled
Power at r/min (kw)	235/2200
Torque at r/min	1250 Nm/1400-1500

GEARBOX	
Make & model	FAW 11509C
Type	9 sp manual Syncromesh
Forward ratios	12.42 - 8.29 - 6.08 - 4.53 3.36 - 2.47 - 1.81 - 1.35 - 1.0
Reverse ratio	12.99

CLUTCH	
Diameter	420 mm
Type	Single plate
Operation	Hydraulic - manual

STEERING	
Gear ratio	20.48
Type	ZF 8098 Recirculating ball
Operation	Power assisted

PERFORMANCE	
Gradeability (atV)	40%
Geared road speed	78 km/hr

AXLES	
Front axle	I-section beam (forged steel)
Rear axle - gearing type	Full floating - single reduction
Rear axle ratio	5.73:1

BRAKES	
System type	Full air - dual circuit
Park/emergency system	Spring brake - rear booster

ELECTRICAL SYSTEM	
System voltage & type	24 v - negative earth
Alternator output	1500 w
Number of batteries	Two
Battery capacity (each)	150 Ah

FUEL TANK	
Number	One
Total capacity	200 litre

CHASSIS	
Front suspension	Semi-elliptic leaf springs with shock absorbers
Rear suspension	Semi-elliptic leaf spring

WHEELS	
Tyre size	12.00 R-20
Rim size	8.50 - 20
Ply rate	18

MASS DATA		
(GVM)	Manufacturer's Gross Vehicle Mass	33 000 Kg
(GCM)	Manufacturer's Gross Combination Mass	33 000 Kg
(GA Front)	Manufacturer's Front Axle Mass	7 500 Kg
(GAU Rear)	Manufacturer's Rear Axle Mass	25 000 Kg
(V)	Permissible Gross Vehicle Mass	25 000 Kg
(D/T)	Permissible Gross Combination Mass	33 000 Kg
(A Front)	Permissible Front Axle Mass	7 000 Kg
(A Rear)	Permissible Rear Axle Mass	18 000 Kg
(T Front)	Unladen Front Axle Mass	4 440 Kg
(T Rear)	Unladen Rear Axle Mass	8 240 Kg
(T)	Total Unladen Mass	12 680 Kg

MAJOR DIMENSIONS	
Wheelbase (WB)	4 075 mm
Overall length (OL)	7 700 mm
Cab length (A)	2 100 mm
Cab width	2 400 mm
Cab height (C)	3 000 mm
Front overhang (D)	1 400 mm
Rear overhang (E)	2 220 mm
Minimum turning radius	9.5 m
Turning circle diameter	19 m
Ground clearance	320 mm
Track	2 065 mm
Chassis outer width	780 mm
Chassis inner width	595 mm

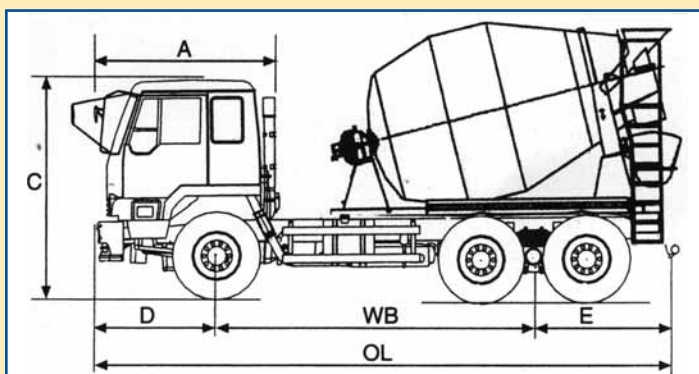

The above specifications are not binding - subject to change without prior notice.



# MODEL 33.330FC



A member of the China FAW Group Corporation - a FORTUNE 500 company • China's largest Truck manufacturer

[www.fawtrucks.co.za](http://www.fawtrucks.co.za)

TOUGH RELIABLE AFFORDABLE