



FAW

MODEL 28.280FD

MODEL	28.280FD
Cab Control	Forward (elect tilt) (aircon)
Seating	Driver + 2 Passengers
Axle Configuration	6x4

ENGINE	
Make & model	Deutz BF6M1013FC
Capacity	7 146 cub.cm
Layout & type	Diesel, water cooled, 6 in line, 4 stroke, turbocharged & intercooled
Power at r/min (kw)	206/2 300
Torque at r/min	1 050/1 400

GEARBOX	
Make & model	FAW 11509C
Type	9 sp manual synchromesh
Forward ratios	12.42, 8.29, 6.08, 4.53 3.36, 2.47, 1.81, 1.35, 1.0
Reverse ratio	12.99

CLUTCH	
Diameter	430 mm
Type	Single plate
Operation	Hydraulic - manual

STEERING	
Gear ratio	20.48
Type	ZF 8098 Recirculating ball
Operation	Power assisted

PERFORMANCE	
Gradeability (atV)	Max 36%
Geared road speed	95 km/hr

AXLES	
Front axle	I-section beam (forged steel)
Rear axle - gearing type	Full floating - single reduction
Rear axle ratio	4.875

BRAKES	
System type	Full air - dual circuit
Park/emergency system	Spring brakes/rear booster

ELECTRICAL SYSTEM	
System voltage & type	24 v - negative earth
Alternator output	1 500 w
Number of batteries	Two
Battery capacity (each)	150 Ah

FUEL TANK	
Number	One
Total capacity	300 litre

CHASSIS	
Front suspension	Semi-elliptic leaf springs with shock absorbers
Rear suspension	Semi-elliptic leaf springs

WHEELS	
Tyre size	12.00 R-22.5 tubeless
Rim size	8.50 - 22.5
Ply rate	16 PR

MASS DATA		
(GVM)	Manufacturer's Gross Vehicle Mass	28 000 Kg
(GCM)	Manufacturer's Gross Combination Mass	50 000 Kg
(GA Front)	Manufacturer's Front Axle Mass	7 500 Kg
(GAU Rear)	Manufacturer's Rear Axle Mass	26 000 Kg
(V)	Permissible Gross Vehicle Mass	25 000 Kg
(D/T)	Permissible Gross Combination Mass	49 440 Kg
(A Front)	Permissible Front Axle Mass	7 000 Kg
(A Rear)	Permissible Rear Axle Mass	18 000 Kg
(T Front)	Unladen Front Axle Mass	3 880 Kg
(T Rear)	Unladen Rear Axle Mass	4 340 Kg
(T)	Total Unladen Mass	8 220 Kg

MAJOR DIMENSIONS	
Wheelbase (WB)	4 075 mm
Overall length (OL)	7 143 mm
Cab length (A)	2 100 mm
Cab width	2 400 mm
Cab height (C)	2 890 mm
Front overhang (D)	1 400 mm
Rear overhang (E)	1 575 mm
Cab to rear axle (CA)	3 275 mm
Cab to end of chassis (F)	4 850 mm
Minimum turning radius	9.5 m
Turning circle diameter	19 m
Ground clearance	315 mm
Track	Front 2 020 mm
	Rear 1 800 mm
Chassis outer width	780 mm
Chassis inner width	595 mm

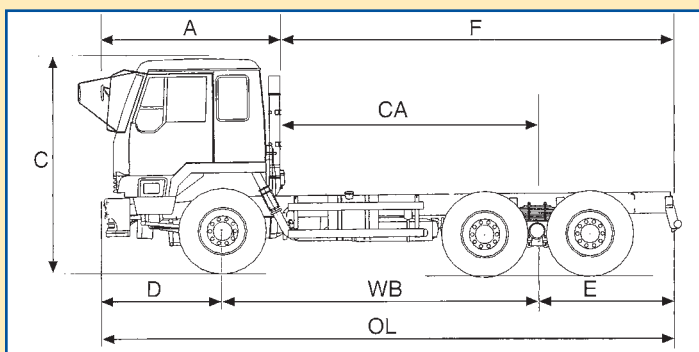

The above specifications are not binding - subject to change without prior notice.



MODEL 28.280FD



A member of the China FAW Group Corporation - a FORTUNE 500 company • China's largest Truck manufacturer

www.fawtrucks.co.za

TOUGH RELIABLE AFFORDABLE